

# MSKSEMI

SEMICONDUCTOR

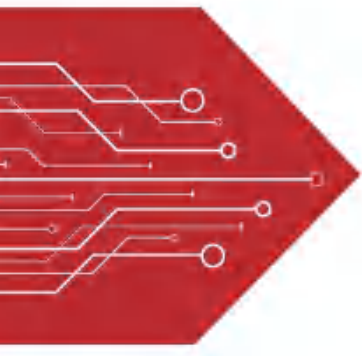

ESD



TVS



TSS



MOV



GDT



PLED

Product data sheet

## FEATURES

- Low forward voltage
- High current capability
- High forward surge capability
- Low power losses, High efficiency
- Guarding for over voltage protection

## APPLICATIONS

Low VF Schottky barrier rectifier are designed for high frequency, miniature switched mode power supplies such as adapters ,lighting and on-board DC/DC conerters

### Primary Characteristic

$I_o$	2*10A
$V_{RRM}$	60V
$I_{FSM}$	300A
$V_F$	0.63V
$T_{Jmax}$	150°C
Assembly code	AJ

## MECHANICAL DATA

- **Case:** Molded plastic
- **Polarity:** As marked
- **Mounting Position:** Any
- **Molded Plastic:** UL Flammability Classification Rating 94V-0
- Lead free in compliance with EU RoHS 2011/65/EU directive
- Solder bath temperature 275°C maximum, 10s per JESD 22-B106

### Maximum Ratings (Per Leg) at Ta=25°C unless otherwise specified

Characteristics	Symbol	Value	Unit
Maximum Repetitive Peak Reverse Voltage	$V_{RRM}$	60	V
Working Peak Reverse Voltage	$V_{RWM}$	60	V
Maximum DC Blocking Voltage	$V_{DC}$	60	V
Maximum Average Forward Rectified Current	$I_o$	Per Leg	10
		Total	20
Peak Forward Surge Current, 8.3 ms Single Half Sine-wave	$I_{FSM}$	300	A
Operating Temperature Range	$T_J$	150	°C
Storage Temperature Range	$T_{STG}$	-40 to +150	°C
Typical Thermal Resistance (Note 1) TO-220AB, TO-263, TO-252 TO-220F	$R_{\theta JC}$	2 4	°C/W

Note1: Thermal resistance from Junction to case per leg mounted on heatsink.

### Electrical Characteristics (Per Leg) unless otherwise specified

Characteristics		Symbol	Value		Unit
Forward Voltage Drop (Note 2)		$V_F$	Typ.	Max.	V
at $I_F=3A$	TA=25°C		0.51	-	
	TA=125°C		0.45	-	
at $I_F=5A$	TA=25°C		0.59	-	
	TA=125°C		0.53	-	
at $I_F=10A$	TA=25°C		0.72	0.78	
	TA=125°C		0.63	-	
Maximum Reverse Current at $V_R=60V$	TA=25°C		$I_R$	3	
	TA=125°C		2	-	mA

Note2: Pulse test: 300 µs pulse width, 1 % duty cycle

## SCHOTTKY BARRIER RECTIFIER



TO-220AB/CT



TO-220F/FCT



TO-263/DC



TO-252/CS

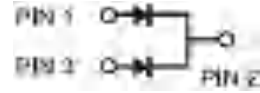

### P/N Information

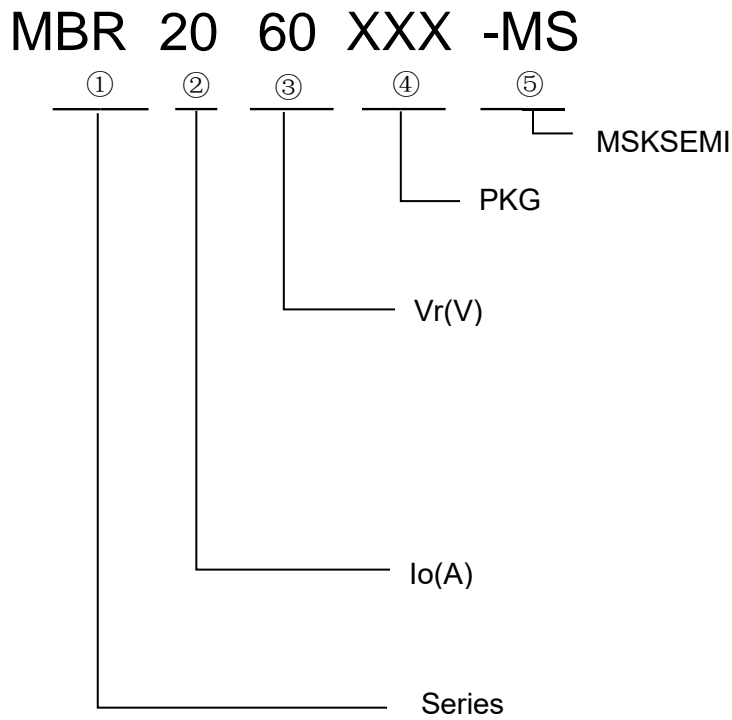

①	②	③	④	⑤
系列	平均整流电流	直流反向耐压	封装	MSKSEMI

**RATINGS AND CHARACTERISTIC CURVES**

FIG.1 MAXIMUM FORWARD CURRENT DERATING CURVE

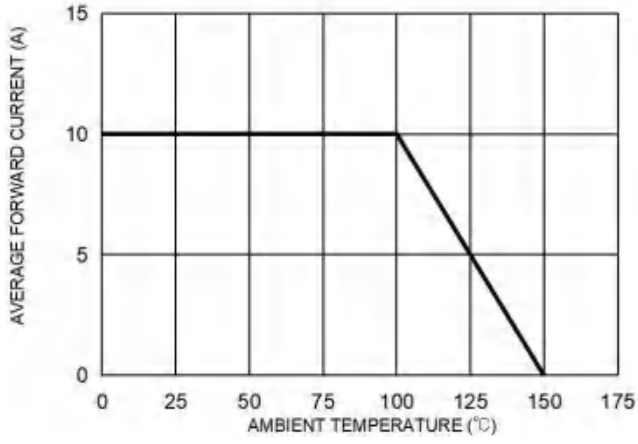

FIG. 2 MAXIMUM NON-REPETITIVE FORWARD SURGE CURRENT PER LEG

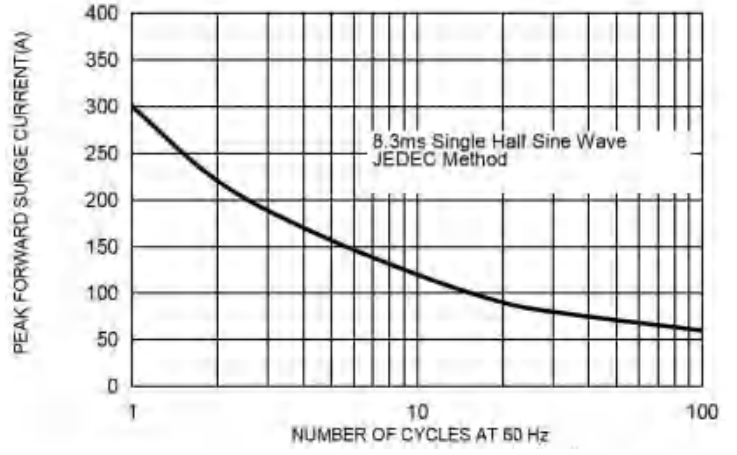

FIG. 3 TYPICAL FORWARD CHARACTERISTICS PER LEG

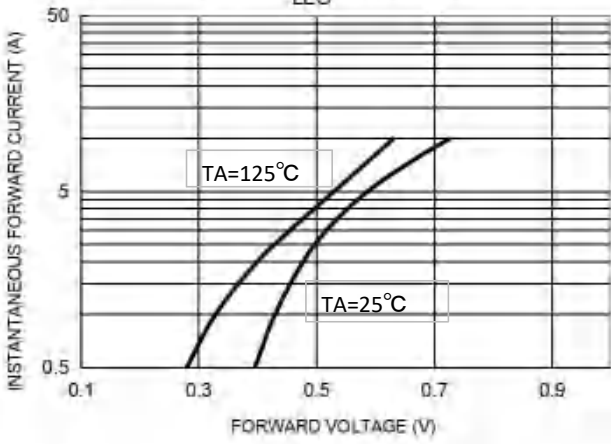
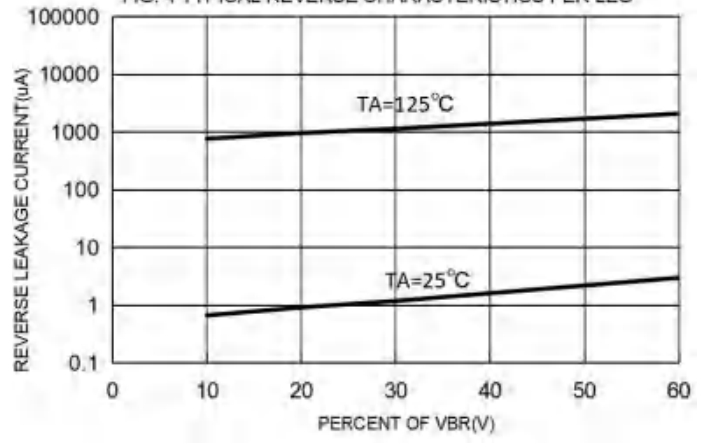
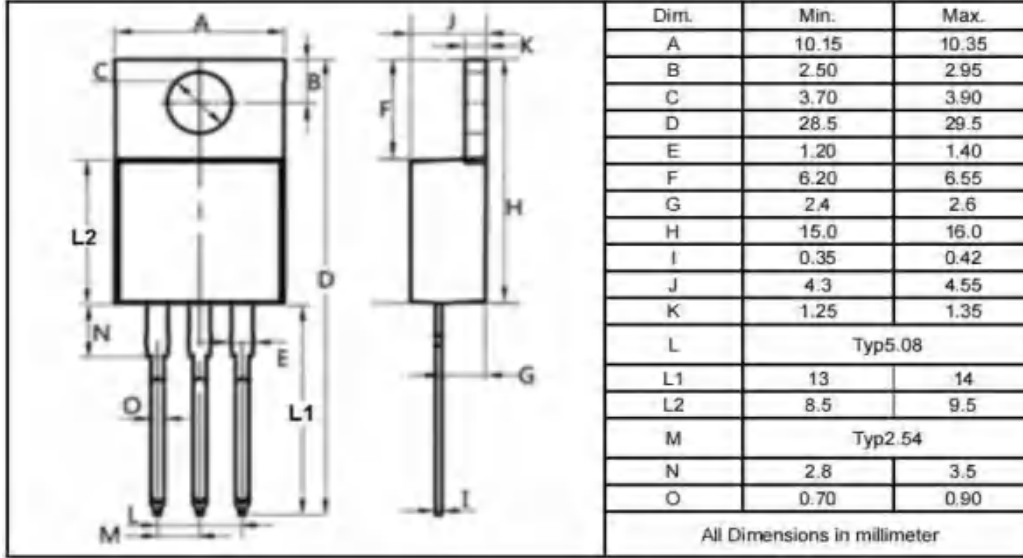

FIG. 4 TYPICAL REVERSE CHARACTERISTICS PER LEG



Package Outline Dimensions millimeters

TO-220AB



**REEL SPECIFICATION**

P/N	PKG	QTY
MBR2060CT-MS	TO-220AB	50pcs/tube 1000pcs/box

Package Outline Dimensions millimeters

TO-220F

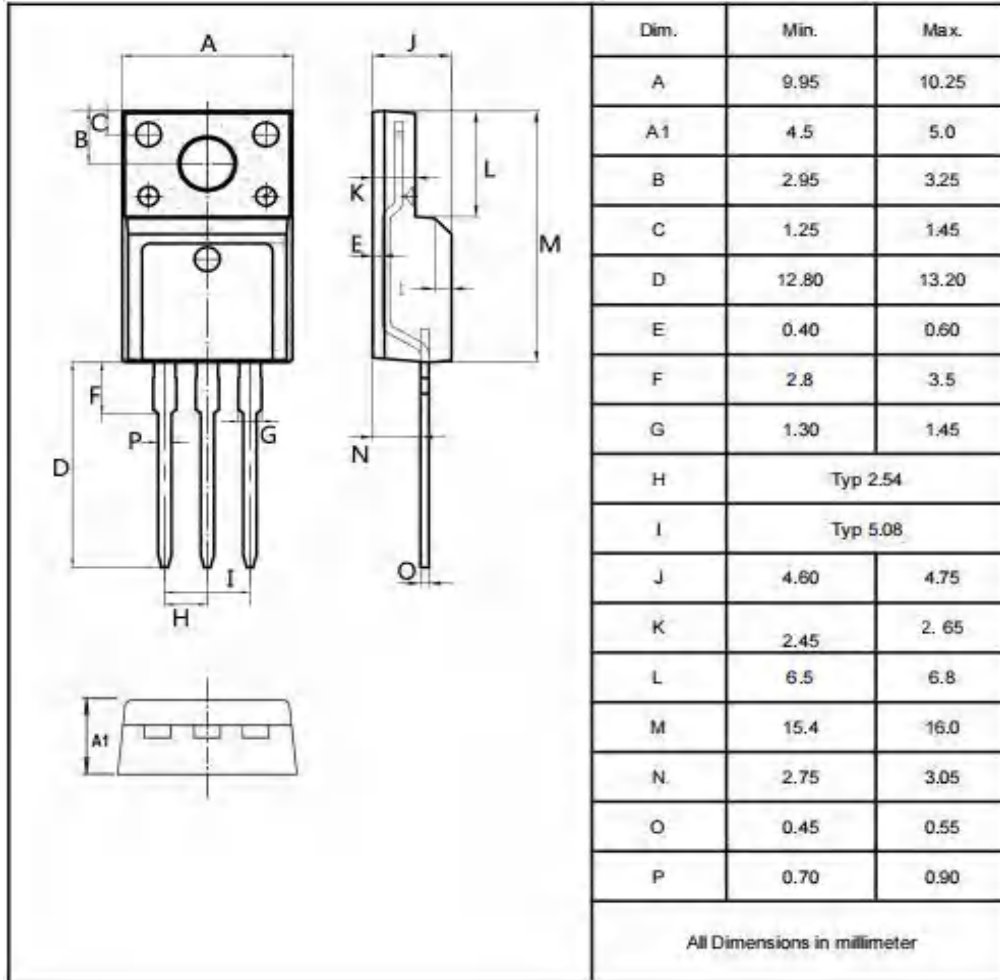

**REEL SPECIFICATION**

P/N	PKG	QTY
MBR2060FCT-MS	TO-220F	50pcs/tube 1000pcs/box

Package Outline Dimensions millimeters

TO-263

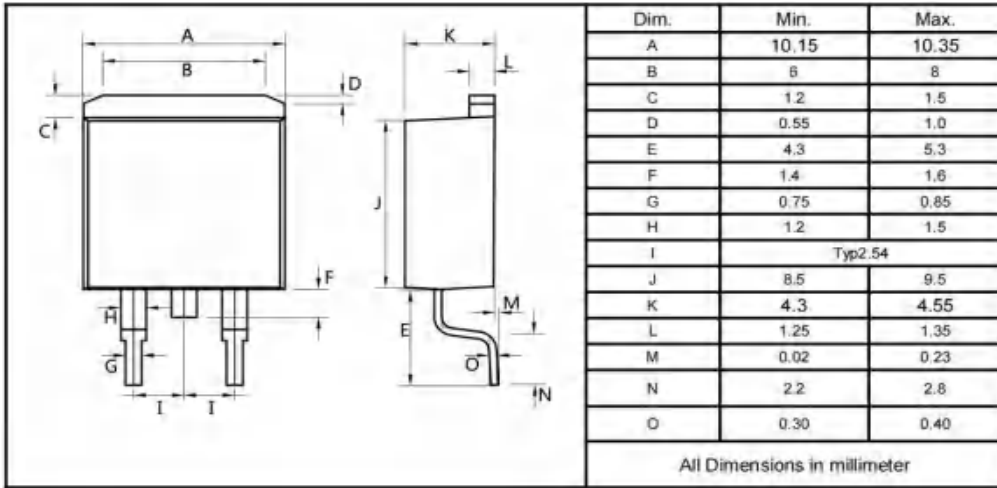

**REEL SPECIFICATION**

P/N	PKG	QTY
MBR2060DC-MS	TO-263	50pcs/tube 1000pcs/box

**REEL SPECIFICATION**

P/N	PKG	QTY
MBR2060DC-R-MS	TO-263	800pcs

Package Outline Dimensions millimeters

TO-252

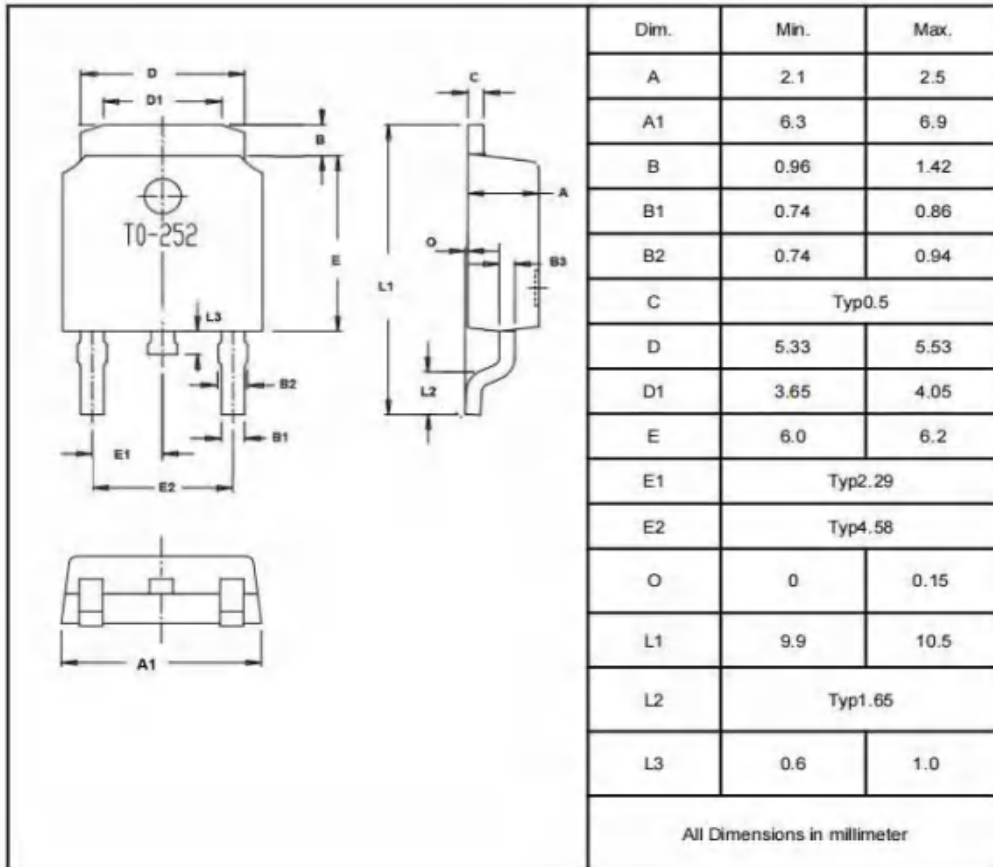

**REEL SPECIFICATION**

P/N	PKG	QTY
MBR2060CS-MS	TO-252	2500



## Attention

- Any and all MSKSEMI Semiconductor products described or contained herein do not have specifications that can handle applications that require extremely high levels of reliability, such as life-support systems, aircraft's control systems, or other applications whose failure can be reasonably expected to result in serious physical and/or material damage. Consult with your MSKSEMI Semiconductor representative nearest you before using any MSKSEMI Semiconductor products described or contained herein in such applications.
- MSKSEMI Semiconductor assumes no responsibility for equipment failures that result from using products at values that exceed, even momentarily, rated values (such as maximum ratings, operating condition ranges, or other parameters) listed in products specifications of any and all MSKSEMI Semiconductor products described or contained herein.
- Specifications of any and all MSKSEMI Semiconductor products described or contained herein stipulate the performance, characteristics, and functions of the described products in the independent state, and are not guarantees of the performance, characteristics, and functions of the described products as mounted in the customer's products or equipment. To verify symptoms and states that cannot be evaluated in an independent device, the customer should always evaluate and test devices mounted in the customer's products or equipment.
- MSKSEMI Semiconductor strives to supply high-quality high-reliability products. However, any and all semiconductor products fail with some probability. It is possible that these probabilistic failures could give rise to accidents or events that could endanger human lives, that could give rise to smoke or fire, or that could cause damage to other property. When designing equipment, adopt safety measures so that these kinds of accidents or events cannot occur. Such measures include but are not limited to protective circuits and error prevention circuits for safe design, redundant design, and structural design.
- In the event that any or all MSKSEMI Semiconductor products (including technical data, services) described or contained herein are controlled under any of applicable local export control laws and regulations, such products must not be exported without obtaining the export license from the authorities concerned in accordance with the above law.
- No part of this publication may be reproduced or transmitted in any form or by any means, electronic or mechanical, including photocopying and recording, or any information storage or retrieval system, or otherwise, without the prior written permission of MSKSEMI Semiconductor.
- Information (including circuit diagrams and circuit parameters) herein is for example only ; it is not guaranteed for volume production. MSKSEMI Semiconductor believes information herein is accurate and reliable, but no guarantees are made or implied regarding its use or any infringement of intellectual property rights or other rights of third parties.
- Any and all information described or contained herein are subject to change without notice due to product/technology improvement, etc. When designing equipment, refer to the "Delivery Specification" for the MSKSEMI Semiconductor product that you intend to use.